

TABLEMATIC PLUS
Tabletop Numbering Machine

INSTRUCTION
And
PARTS MANUAL



TABLEMATIC PLUS NUMBERING MACHINE

The TABLEMATIC-Plus is a versatile and portable numbering machine, easy to operate by anyone in the shop. By simply adjusting the position of the numbering head, one can number anywhere on a sheet. The operator can choose to register a number by using the built-in side guides on the machine and using the magnetic backstop. The foot switch activates the unit, then the operator's hands are free to guide the paper into position. The Tablematic Plus is ideal for short run numbering (invoices, forms, etc.) and is perfect for crash numbering as many as 6 multi part forms. Count has developed a convenient patented ink cartridge that provides continuous ink flow; no re-inking required. Each cartridge will produce approximately up to 20,000 impressions.

SPECIFICATIONS

Power Source: 115-120V 50/60 cycle, 3 amp. (or 220 volts if ordered)
Control Panel: 1 - wire outlet, circuit breaker, Printed Circuit Board, on/off switch with light.
Snipping Weight: 19 lbs. (Single Head)
Deimensions: Work-base, 11 1/2" x 15 1/2" Over-all 18 1/2" x 12" x 9"

SAFETY PROCEDURES FOR SAFE OPERATION

Before Numbering

- Read the Owner's Manual and carefully follow the instructions.
Warning: Electric shock could occur if used under wet conditions.
- Always use a grounded outlet and a grounded circuit
- Do not use ungrounded equipment on the same circuit
- Keep the cords clear from any moving parts.
- If you leave the numbering machine unattended, turn unit off.

While Numbering

- Feed sheets or forms in one at a time; do not pile them up on the platen and the pull them out.
- Do not build up the platen area with cardboard or any other material.

After Use:

- Turn off the unit at the control panel. Then, unplug the main power cord.
- To unplug the main power cord, always grasp the plug at the outlet, and NEVER pull on the cord to disconnect.
- Unplug the power cord from the head before cleaning the numbering wheels.

Do not attempt to dismantle the TABLEMATIC - Plus. If for some reason the unit does not function properly under Warranty, return prepaid to COUNT NUMBERING MACHINE, INC. with a written explanation of what is wrong. Warranty will be voided if unit is disassembled.

NOTE: When returning number head for repairs, always remove ink cartridge to avoid additional cleaning charges.

BE ALERT! Be Careful! Never let fingers get too close to the numbering Head.

We strive for continued improvements in our equipment line. Therefore, we reserve the right to change specifications without notice or liability to existing Count equipment in the field.

TABLEMATIC-PLUS ILLUSTRATION

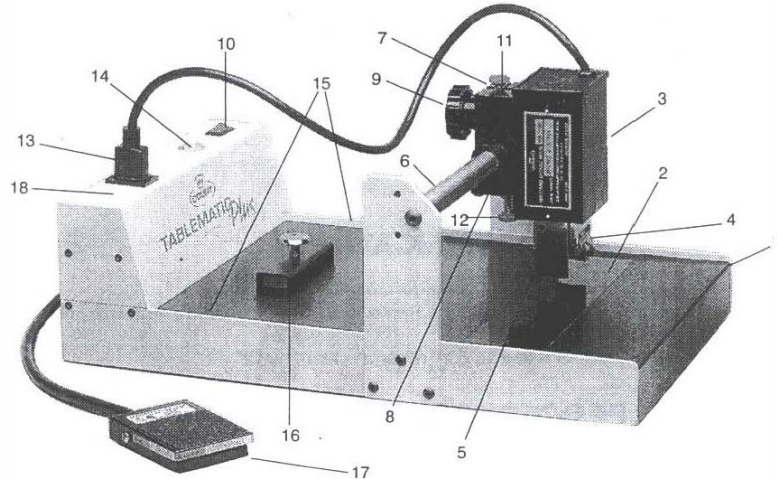

- | | |
|---------------------------|--|
| 1. TABLE/work base | 10. ON/OFF Switch |
| 2. Platen | 11. Vertical adjust pressure |
| 3. Numbering Head | 12. Horizontal adjust screw |
| 4. Action Indicator | 13. Electrical Outlet For Numbering Head |
| 5. Ink Cartridge Holder | 14. Circuit Breaker |
| 6. Cross Bar | 15. Built-in Side Guides |
| 7. Head Block Bracket | 16. Magnetic Backstop |
| 8. Head Leveling Bracket | 17. Foot Pedal |
| 9. Knurled Knob 1/4" - 20 | 18. Control Panel |
| Head Lock Down Knob | |

Place the TABLEMATIC Plus on an uncluttered, sturdy desk, conveniently located near a 115V grounded outlet. Place the footswitch on the floor and plug the main power cord into the nearby outlet. **DO NOT USE UNGROUNDED EQUIPMENT ON THE SAME CIRCUIT.**

LIMITED WARRANTY

Count Machinery Company warrants its equipment against defective parts or workmanship under normal use and service for a period of: (1) year on all electrical and other parts; (90) days on numbering heads. During this time, COUNT will either repair or replace any COUNT unit returned (shipping prepaid) which, after examination by us, is determined to be defective. All freight charges for equipment sent in for warranty service is the responsibility of the purchaser and must be prepaid. Count will not be held responsible for any shipping charges. You may request your desired shipping method when the product is returned. If no method is stated Count will send the time back UPS Ground. This warranty will be voided, if the product has been repaired or altered by anyone except for Count, or which has been subjected to misuse, negligence, or accident. Under no circumstances will Count be liable for consequential damages. The user shall determine the suitability of the product for the intended use and the user assumes all risk and liability whatsoever in connection herewith. For service, return the unit prepaid with written explanation of service needed to:
 COUNT MACHINERY COMPANY 2128 Vineyard Ave. Escondido, CA. 92029, 760-489-1400 Fax: 760-489-1543.

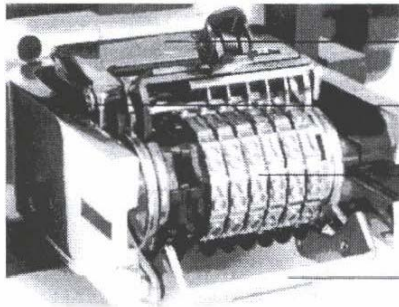

**Action Indicator/
Repeat Selector**

Action Indicator/
Repeat Selector - S-AAM-0870

**Action Indicator
Shaft & C Clip**

Wheel Assembly - H-1125

**Wheel
Assembly**

Ink Cartridge
Swing Arm - S-UNS-0912

Action Indicator
Shaft & C-Clip - H-1176

**Ink Cartridge
Swing Arm**

DEPRESSING A WHEEL



The standard Numbering Head is capable of recessing the first three wheels so there is no image when striking. For example, to print the number 4750 instead of 004750, you will need to depress the first two wheels. To do so, remove the Numbering Head from the Head Bracket and hold it upside down resting it on a flat surface.

Swing the Ink Cartridge away from the wheels (or remove). Rotate the 1st wheel until the 9 is in the up position. Then press forward slightly and down, you will feel the wheel depress below the level of the others. Do the same to the 2nd wheel. Now you can print a 4 digit number. To return to position, simply rotate the wheel and it will pop up. This feature is also available on the custom Numbering Wheel with letters. Rotate the wheel until the blank position is up then press forward and down.

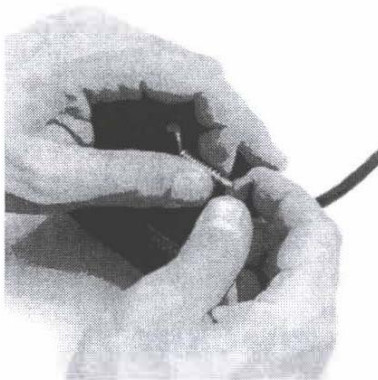

CHANGING DIRECTION OF THE HEAD

The Numbering Head is capable of rotating 270 degrees in 90 degree increments. To change the direction, simply remove the Vertical Bracket (using the 5/32 Wrench Supplied) and reinstall on the desired side. NOTE: To get to the Upper Mounting Screw for the Vertical Bracket, you must remove the Lock Knob and Pressure Adjustment Screw first. Take notice of how far the Adjustment Screw extends below the Stem so that when replacing you have a reference point. When replacing the

Pressure Adjustment Screw, compress the spring slightly before trying to screw in the Adjustment Screw. This is a very fine thread and can easily be started incorrectly leading to thread damage. Do not try to press the Spring in with the Adjust Screw and turn at the same time. (Trust Us!) See photo.

FUNCTION OF HEAD BRACKETS

For direction purposes we will call the mounting of the Vertical Bracket. In this position:

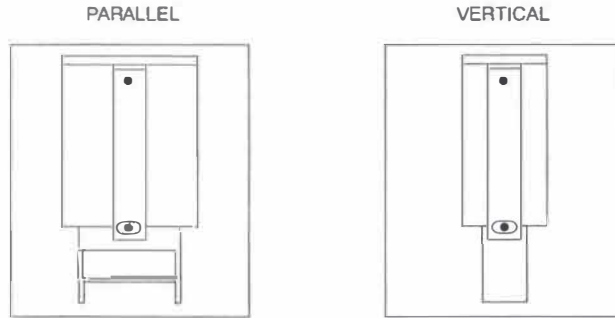

It is important to be familiar with the adjustment of the brackets. Shown below are the various adjustments and the effect they have on the image of the number.

Depending on the orientation of the head the adjustment of the Vertical Bracket can be either:

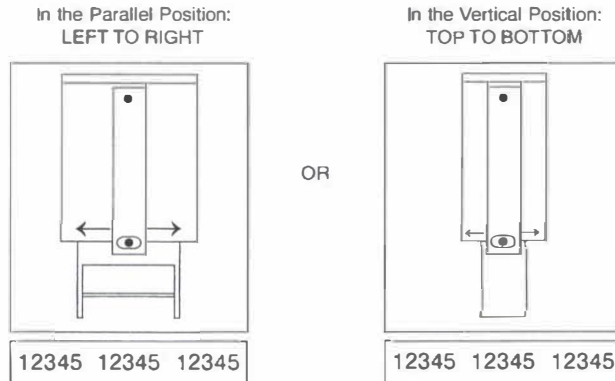

ADJUSTING THE VERTICAL BRACKET

The bottom of the vertical bracket is slotted to allow for movement. The effect of this movement depends on the orientation of the head (See Function of Head Brackets). To make an adjustment to the vertical bracket, simply loosen the lower screw and slide toward the direction desired, then retighten the screw. It is not necessary to loosen the top screw.

ADJUSTING FOR A LEVEL IMPRESSION

To begin the leveling process, move your numbering head's to the desired lateral position on the bar. To do this you must first loosen the mounting bracket cap screws (item #1.) Then loosen the head lock down knob (item #2.) When these are both released, the head and bracket will slide along the bar. By using your horizontal adjust screw (item #3.) Along with your vertical adjust pressure screw (item #4.) Thus allowing for fine adjustment to pressure as well as levelness prior to tightening lock down knob and mount bracket cap screws. You are now ready to number.

TOP TO BOTTOM

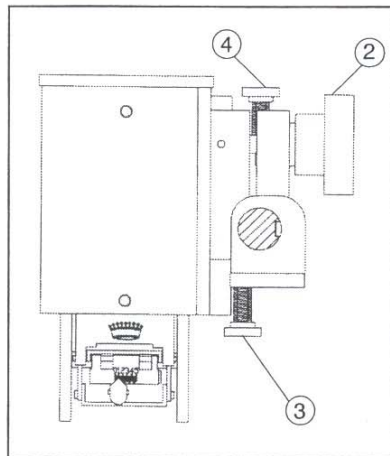

LEFT TO RIGHT

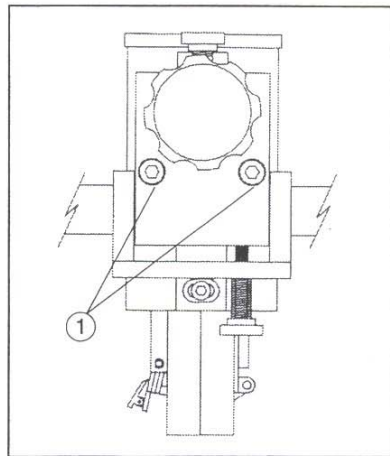

TIPS FOR LEVELING HEAD

Leveling the numbering head is the most critical part of the set up process. If the head is not level you will get a blurred or "Ghosted" Impression. This can also occur when the head is set to hit too lightly or too heavy. Never set pressure to favor the drop wheels, for this will depreciate the life of the numbering wheels. The easiest way to check your impression is to use a 3 part carbonless set. Program the TABLEMATIC-Plus to stamp in one location anywhere on the sheet. Run your test sheet through the machine and check impression for pressure as well as levelness. By level we mean a level impression. Where the impression of the 1st digit is the same pressure and impression as the 5th and 6th digit always favoring the 1st digit slightly. And the top of the digits is the same as the bottom. We do not mean "plumb level," as using a small level will not help.

SETTING THE ACTION INDICATOR/ REPEAT SELECTOR

This allows you to select the number of times that the head will strike without advancing to the next number.
EXAMPLE: If you need to number a job which requires the same number in two (2) positions, slide the selector to "2." The head will now strike the same number twice.

NOTE: After selecting a repeat sequence, replace head and run a test sheet through the TABLEMATIC-Plus.

You should get this:

100 100	99 99	98 98
---------	-------	-------

If you get this:

100 99	99 98	98 97
--------	-------	-------

the number changes at the wrong strike, the wheel cam is not in sync with the paper. To remedy this, you must get the head to fire 1 time. This can be done by programming in a single strike and running a sheet through or run a sheet through with the existing program and quickly unplug the head after the first strike. Once you have achieved a single strike the cam is now in the correct changing sequence.

REPLACING THE ACTION INDICATOR (REPEAT SELECTOR)

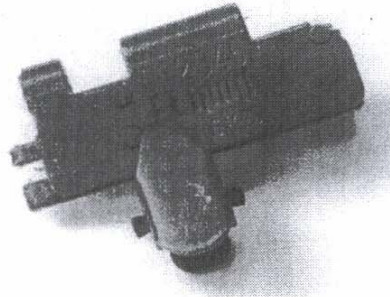

The photo above shows a broken selector. If the selector has broken, it can be easily replaced with a small screwdriver and a pair of needle nose pliers.

First, remove the "C" clip from either end of the shaft and slide shaft out. The spring will sometimes catch on the end of the shaft. If the shaft gets hung up, use your needle nose pliers to jiggle the spring and pull the shaft out. Place the new selector in position and place the new springs in their location, making sure the springs are in their guide holes. Slide the new shaft through and place "C" clips on each end.

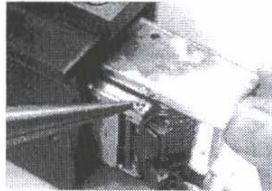

Removing the "C" clip

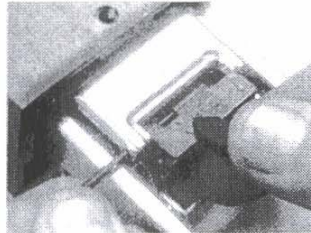

Replacing the shaft

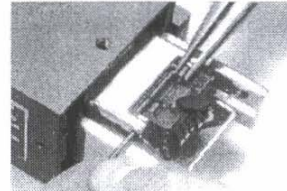

Installing the new springs

Now, with your needle nose pliers, pull the spring ends lightly until it stops, bend end of spring over and cut off excess wire. This will tighten the return action of the selector.

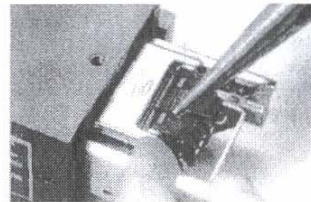
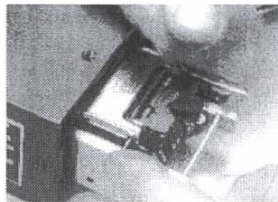

INK CARTRIDGE

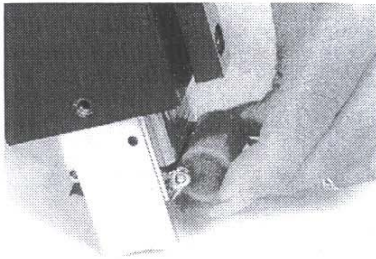

Photo A

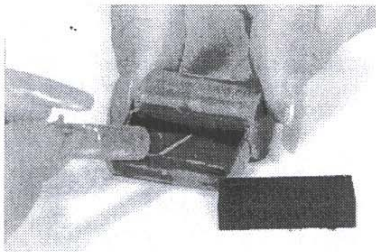

Photo B

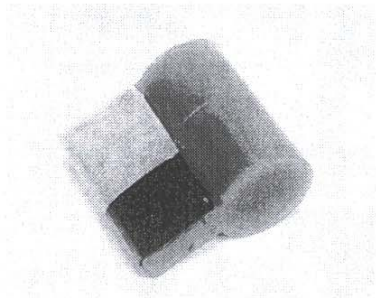

Photo C

The ink cartridge slides under the swing arm and locks into place. (Photo A) When installing a new ink cartridge, first remove the foam pad using an x-acto knife and place a small cut into the reservoir (Photo B). This will supply ink to the foam through the action of the swing arm. Start with a small hole as it is easier to make the hole larger, but if you start with the hole too large you cannot control the flow of the ink.

NOTE: The flow of ink can be sensitive to temperature. On a cold day the ink will be thicker and not flow easily, whereas on a hot day the ink will be thin and flows faster. Also, be sure to shake cartridge well.

We also suggest that when opening a new cartridge, use the piece of tape which holds the cover on to wrap around the cartridge about 1/4 of an inch (Photo C). This will help reduce excess ink on the numbering head especially when only using 3 or 4 digits where the foam would have a tendency to lift on the opposite side.

INK CARTRIDGE (for re-order)

RED (6-pack)	S-UNS-0060
BLACK (6-pack)	S-UNS-0050
BLACK/RED (6-pack)	S-UNS-0030
RED (10-pack)	S-UNS-0080
BLACK (10-pack)	S-UNS-0070
BLACK/RED (10-pack)	S-UNS-0040



251 Wedcor Avenue, Wabash, Indiana 46992

Website: www.countmachinery.com Email: Info@martinyale.com

Fax: (260) 563-4575