

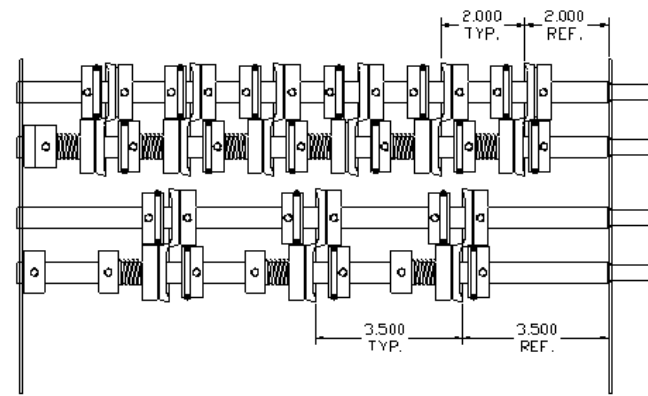

Operating Instructions BCS200 series

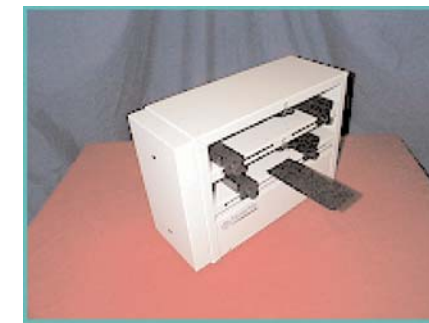

10 UP FORMAT

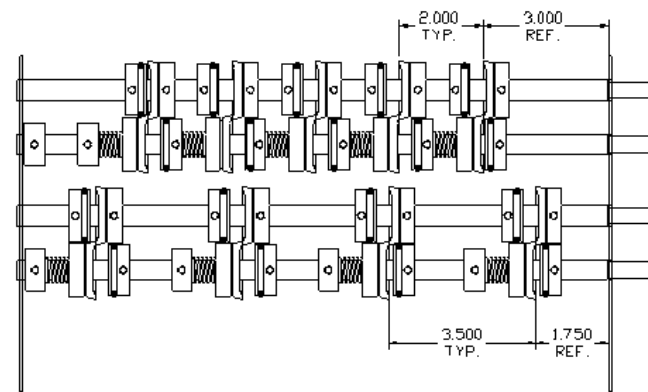

12 UP FORMAT

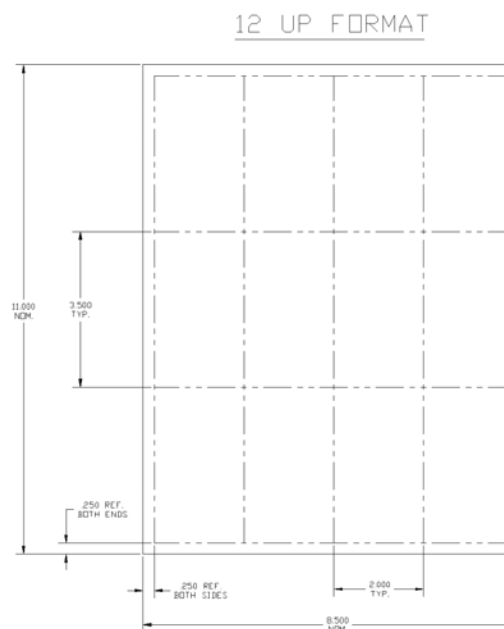
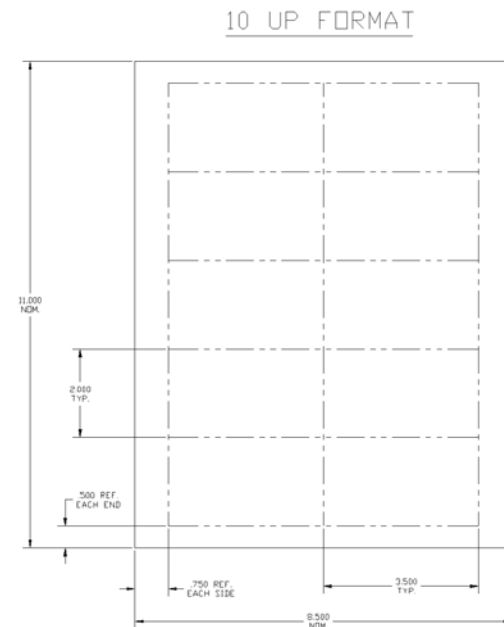

1.0 Introduction

Thank you for your purchase of the Martin Yale line of Business Card Slitters. With proper maintenance your unit will provide you with years of service. Upon receiving the machine verify that there are no signs of shipping damage on the exterior. If you feel the product may have been damaged in transit, contact the appropriate freight carrier immediately, then contact technical support at Martin Yale Industries, Inc. at 260-563-0641.

Upon opening the machine, verify that you have the following components.

2.0 Inventory of Contents

- BCS200 Series
- BCS200 Series Unit
- Receiver Tray W-ODT0024
- Receiver Base Form W-ODT0023
- Paper Support W-ODT1124
- 10 - Up Catch Tray W-ODT0021
- 12 - Up Catch Tray W-ODT0020
- Operating Instructions
- 8.5" Top Plate W-ODT0100
- 11.0" Top Plate W-ODT0200

Model:
Serial No:
Manuf. Date:

3.0 Specifications

- > Units will handle 24# bond to 100# cover stock.
- > Min. Sheet Size 4 1/8" X 3 1/2"
- > Max. Sheet Size 8 1/2" X 11"
- > Speed: BCS212: 300 finished cards per minute.
BCS210: 375 finished cards per minute.



251 Wedcor Avenue • Wabash, Indiana 46992

Phone (260) 563-0641 • Fax (260) 563-4575

Email: info@martinyale.com • Website: www.martinyale.com

4.0 Set up from carton to table

Caution: The unit contains rotating blades and other dangerous items. Do not remove any safety covers from the machine. Be aware that loose jewelry, long hair and loose fitting clothes should be kept away from the unit.

1. Set the machine on a tabletop. Verify the power switch is set to "0" (off position).
2. Look in each feed shelf of your unit, and verify that the tips of the sheet retarder are not in contact with the feed wheels. These are preset at the factory and should not need to be adjusted. **Note: If the machine is operated with the retarder in contact with the feed wheels the wheels could be damaged.**

Make sure that the sheet retarder tips are not touching the feed wheel in each shelf when the machine is turned on.

Retarder is factory set to .012 gap and should not need to be adjusted for typical 65# stock.

Retarder

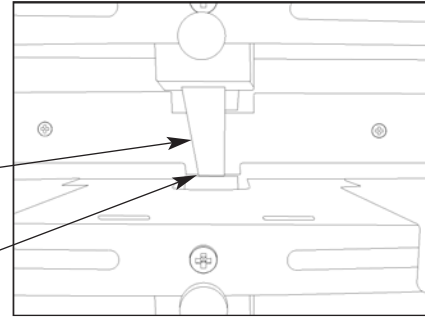

Figure 1

- 2a. Remove taped accessories from the exit tray shelves. These are used as paper weights on top of the stack to insure accurate tracking of curled stocks, or for stocks that require additional control for accurate feeding and registration. See Figure 2.

Make sure that the stack weights are removed from the feed bins before the machine is run for the first time.



Figure 2

3. Turn rocker switch to "1". The unit should begin running. If there is no power, try the following:
 - 3a. Check the electrical outlet to verify function. A good way to do this is to plug in another device that you know works.
 - 3b. If still no power, check that circuit breaker has not tripped. Find source of machine bind and correct. Allow machine to cool and push breaker in to reset.
 - 3c. Call the technical support division at Martin Yale Industries, Inc. at 260-563-0641.

4.1 Tray/ Paper Support Installation

A paper support is utilized on the in feed of any bin where the sheets overhang the edge of the feed shelf. The paper support is installed by inserting the tabs into the slots on the front of the feed shelves as shown in Figure 3. Install the paper support and collection bins onto the machine as shown in Figure 4. Keep in mind the bottom shelf will be where the first pass is made and the shelf above it will be where the finished product is created.

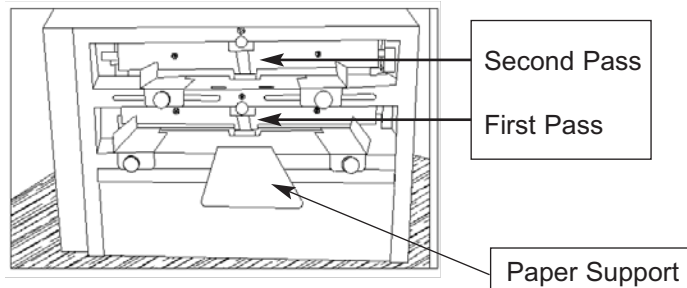

Figure 3

Collection bin for finished cards goes on top shelf; large collection tray goes on bottom.

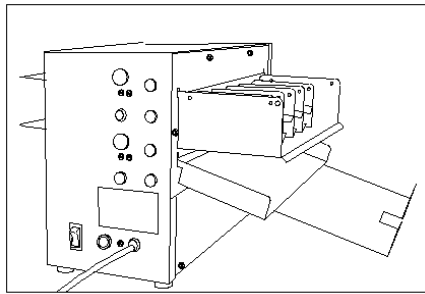
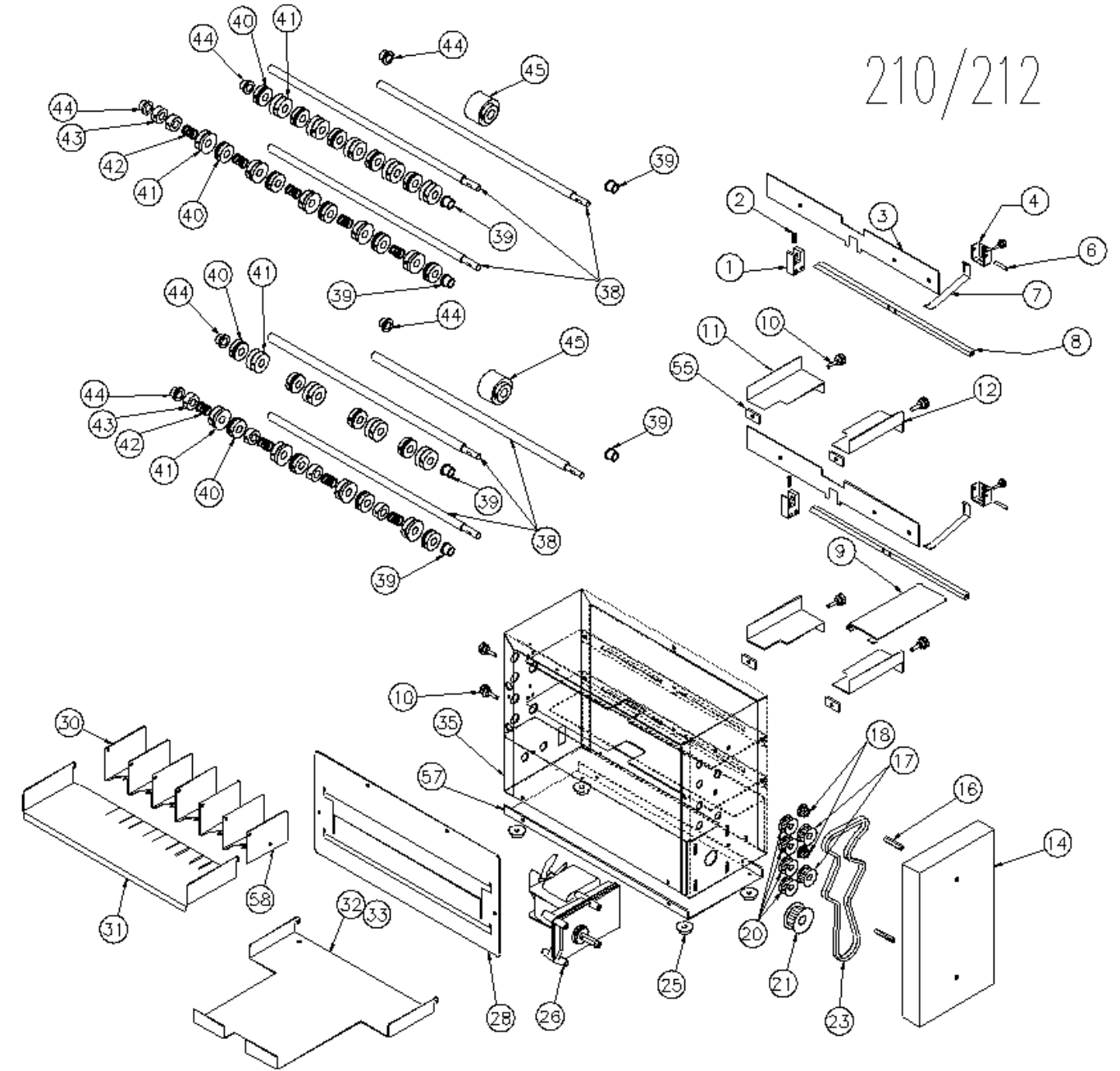

Figure 4



BCS 210/212 Parts List

Item	Part No.	Description	Item	Part No.	Description
1.	W-ODT0019	Adjustment Block	26.	M-S021073	Motor
2.	M-S031092	Spring	28.	W-ODT0008	Rear Cover
3.	W-ODT0015	Sheet Separator	30.	W-ODT0024	Receiver Tray
4.	W-IDT1119	Feed Bracket	31.	W-ODT0023	Receiver Base Form
6.	M-S019033	Stand Off	32.	W-ODT0021	10 Up Catch Tray
7.	W-ODT1123	Pressure Finger	33.	W-ODT0020	12 Up Catch Tray (not shown)
8.	W-ODT0016	Adjust Bar	35.	W-ODT0002	Housing Assembly
9.	W-ODT1124	Paper Support	38.	W-ODT0017	Slitter Shaft
10.	M-S032007	Knob	39.	M-S014029	3/8 Clip Bearing
11.	W-ODT0014	Right Hand Guide	40.	W-ODT0115	Tension Collar
12.	W-ODT0013	Left Hand Guide	41.	M-ODT1105	Blade
14.	W-ODT0011	Drive Cover	42.	M-S031091	Blade Spring
16.	M-S019033	Stand Off	43.	M-O200134	1/2" Set Collar
17.	M-S022132	15T Pulley	44.	M-S014030	1/2 Clip Bearing
18.	M-S022130	10T Pulley	45.	WRAOGC0026	Feed Roller w/ set screw
20.	M-S022131	14T Pulley	55.	W-ODT0107	Spacer
21.	M-S63751563	Pulley 20XL	57.	W-ODT0022	Base
23.	M-S025053	95T Double Sided Belt	58.	W-ODT0025	End Plate
25.	M-S030045	Bumpers			

BCS 210/212 Wiring Diagram

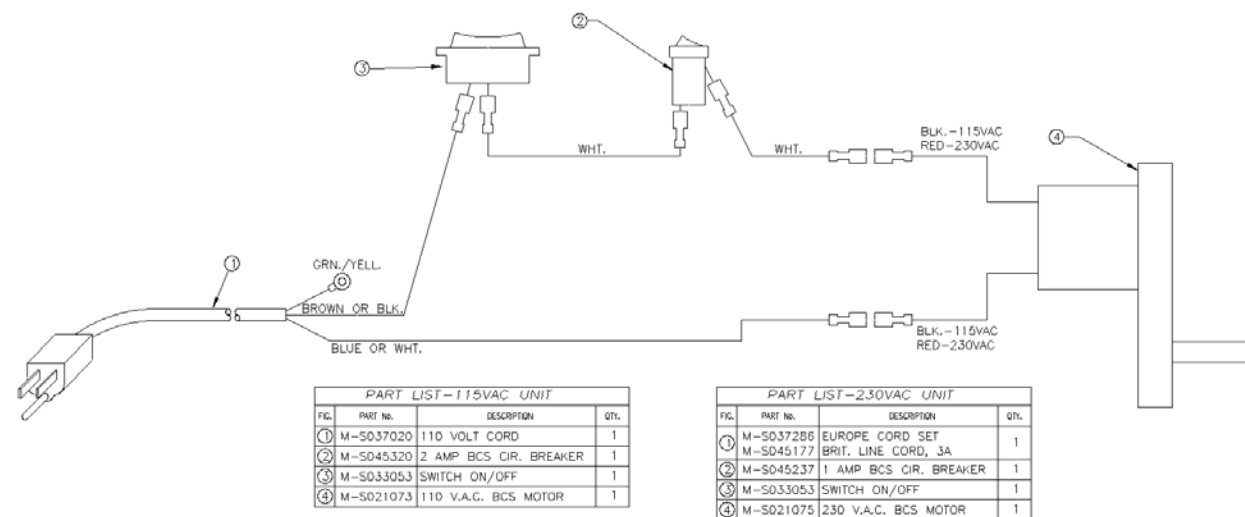

5.0 Setting Registration

Note: The registration is preset at the factory and should not be adjusted unless it is determined that it is not correct for the stock being used.

Perform the following steps in order to achieve accurate registration.

- Loosen the thumb knobs on the paper guides for the appropriate shelf (see Figure 5).
- Raise retarder up using the thumb knob on the side of the machine (rotate counter-clockwise) until stock will easily slide under retarder (Figure 7, Below.)
- Align register marks on layout sheets with the cutter blade edges (Figure 8).
- Position paper guides so that side-to-side movement will be no more than 1/32". NOTE: The guides should not pinch the stock. Inaccurate feeding could result if too tight (Figure 9).
- Feed single sheets to test for accuracy. Readjust paper guides as necessary.

NOTE: You may want to use unprinted stock for initial start up to remove residual oil from cutting blades.

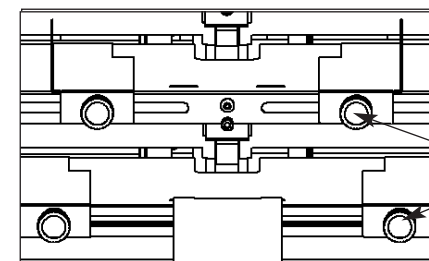

Figure 5

Paper Guide
Thumb Knobs
(2 Pairs)

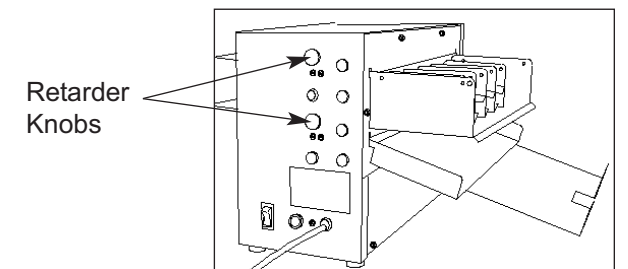

Figure 6

Retarder
Knobs

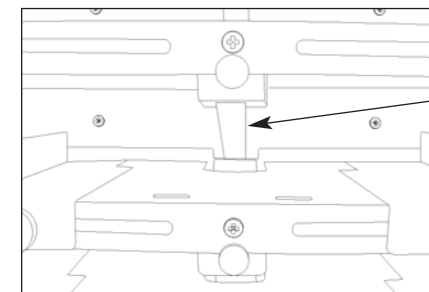

Figure 7

Stock
Retarder

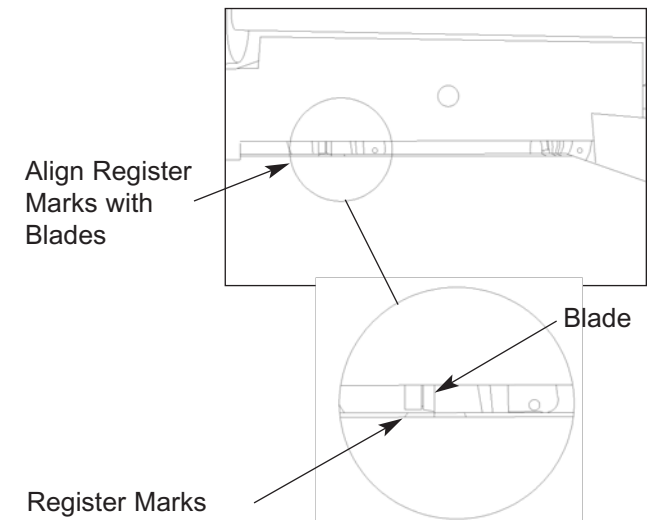

Figure 8

Align Register
Marks with
Blades

Blade

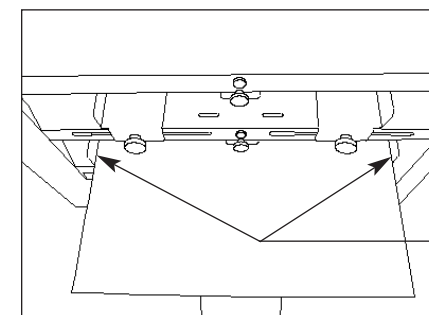

Figure 9

Paper Guide to
Stock Adjustment
Watch for Pinching of
Stock at These Points

Register Marks
(on Layout Sheet)

Verifying a square cut:

To verify that the finished product is square, take a stack of business cards and divide in half. Flip 1/2 over and recombine. All edges should align evenly. If edges do not align, the stock is skewing. See skewing section under 6.0 Troubleshooting.

5.1 Proper Feeding

NOTE: The feed is preset for 65# stock and typically does not require readjustment. Registration should be set before setting the retarder for single sheet feeding.

Follow these steps:

1. Using the adjustment knob on the front of the feed shelf, position feed pressure arm so that it is just above the feed wheel. Make sure there is no contact. (Figure 10).

Pressure arm should rest just out of contact with the feed wheel.

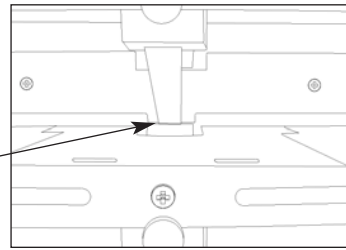

Figure 10

2. Using the adjustment knob on side of feed shelf, raise retarder off feed wheel. Insert one piece of stock to be ran in between the retarder and feed wheel so that sheet passes freely. Lower retarder so that there is a slight drag on the stock as it is pulled out.
3. Place a neat stack of three sheets into the unit and test. Readjust as necessary until one sheet feeds steadily.

Feeding Thermographic or severely curled stock:

In some applications a hesitant feed can occur if the raise of the lettering prevents the sheet retarder from functioning normally. This can also occur with heavier stocks should they develop a curl when printed.

Should this become an issue, the following steps can be performed:

1. Run stock through image side down.
2. Apply some weight to the stock for a period of time before it is to be run.
3. Use the 8.5" and 11.0" weights on top of the stack.

Should stock still have feed issues call technical support at Martin Yale Industries, Inc. at 260-563-0641.

Obtaining Service

Should your machine need to be professionally serviced, Martin Yale Industries, Inc. can refer you to the nearest Factory Authorized Technician. Contact us at the phone number given above.

6.0 Troubleshooting

Multiple Sheet Feeding:

1. Set feed system per Section 5.1.
2. If stock is glossy the feed wheels of the machine may have grip issues. This is a common issue with friction-fed units. If one side is not glossy, run through with glossy side facing up.

Inaccurate Registration:

1. Set registration on unit per Section 5.0.
2. Double-check the layout to make sure that the register marks are being utilized in the proper manner.
3. Verify that locking knobs in the paper guides are tight. **NOTE: DO NOT OVERTIGHTEN LOCKING KNOBS.**
4. Check o-rings on the unit for signs of wear and tear. Clean paper dust off component.
5. Check the upper extreme left O-ring and the extreme lower right O-ring. Verify that the document is going under these on both sides. Readjust as necessary. If the document does not go under these on both sides it will cause the document to skew to one side.

Stacking Issues:

If business cards do not properly fall into slots:

1. Slide the collection tray as the machine runs to fine-tune positioning.
2. Make sure collection trays are not obstructed. They should hang freely from the exit side of the unit.

Skewing:

1. Most often occurs during the second cut (2" width) on business cards slitters. Check that paper guides are properly adjusted to give minimal side clearance on material and still allow stock to slide freely.
2. In the event the machine is properly set and a slight skewing may still occur, loosen the setscrew (A) in both of the collars with O-rings and slide collars inward (B) until slight resistance is felt. Do not push collar into slitter blade (C), as this will affect slitting quality. Retighten setscrews (A) after relocation and before operation. See diagram at right. Moving O-ring collars usually requires some amount of trial and error. It should only be attempted after all the above recommendations have been exhausted.

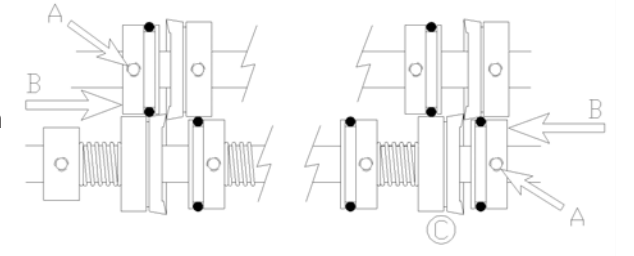

6.1 Maintenance

Proper maintenance of your unit will prevent most situations that cause damage. Follow the steps below to maintain the unit.

1. Once every 60 days, clean all paper dust from the unit.
2. Once every 90 days, check the Phillips head screws in each sheet retarder and make sure they are tight.
3. Periodically, check the power cord of the machine for frays and pinches. Replace cord should any damage be found.
4. As needed, clean feed wheels on the unit with mild cleaner and a soft cloth.
5. Periodically clean the O-rings on the cutter shafts with a damp, soft cloth.
6. In the event of blade removal during the life of the machine, a diagram of blade placement has been included for reassembly purposes. See Figure next page. **CAUTION: Blade spacing and tension is extremely critical to the operation of any business card slitter. Only a qualified service technician should attempt blade removal/replacement.**