

POWERLINE  **MARTIN YALE**
INDUSTRIES
REAM CUTTER

620RC

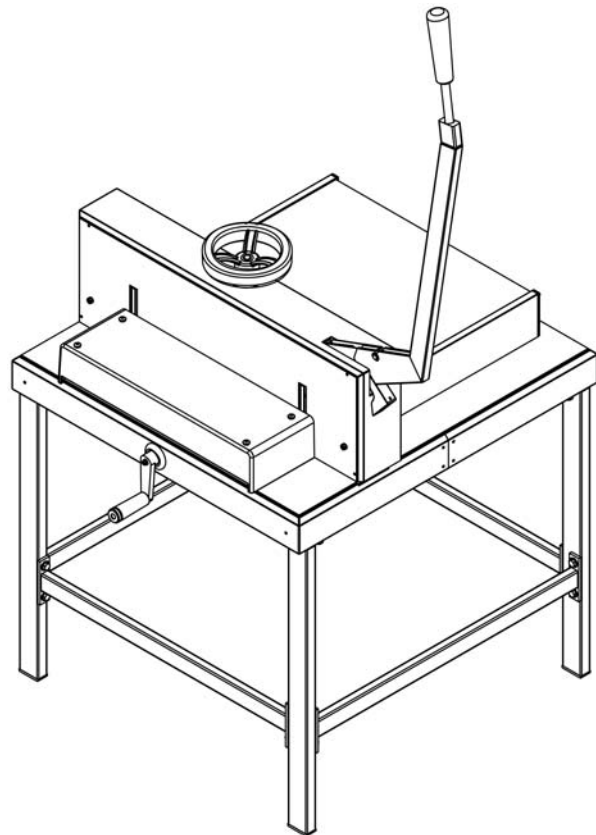

User's Guide

620RC 18" Manual Ream Cutter



Martin Yale Industries, Inc. is a manufacturer of office equipment forms and document handling products, paper trimmers, and graphic arts products for the printing professional and modern electronic publishers.

| Model 620RC Specifications | Table of Contents |
|--|------------------------------------|
| Cutting Height 3.15" (80mm) | Introduction 2 |
| Width Capacity 18½" (470mm) | Safety Rules 2 |
| Length Capacity 18.70" (475mm) | Nomenclature 3 |
| Cutting Method Lever | Components Description 3 |
| Clamping Method Manual Handwheel | Intallation 5 |
| Dimensions 33" x 35¾" x 20½" | Operation 5 |
| Machine Weight 195 lbs. (88.45 kg) | Blade Sharpening 6 |
| | Cutting Stick 6 |
| | Lubrication 6 |
| | Maintenance 6 |
| | Blade Replacement 7 |

Serial # _____

INTRODUCTION

Thank you for selecting the Martin Yale PowerLine Model 620RC Ream Cutter. The Model 620RC will cut many varieties of paper and light cardboard and is designed to provide a high level of safety, accuracy, flexibility, and ease of operation. With recommended maintenance, the unit will provide years of trouble-free service. Please review this publication in its entirety before attempting to operate your Model 620RC. Thorough understanding of this information will help eliminate most operator-associated errors and ensure years of trouble-free performance.

WARNING! *The cutting blade of the Model 620RC is extremely sharp. Never place hands or fingers under the cutting blade or into the cutting area. Serious bodily injury could result. To prevent injury, do not operate the machine with any covers removed or safety features disabled, and cut only paper materials. The front blade guard must be in the lowered position before the blade will operate. Never allow children to operate the 620RC unsupervised.*

SAFETY RULES

- Please read and understand this manual completely before attempting to operate the folder
- This machine is designed for individual use only. No more than one person should be operating the machine at any given time.
- Always use both hands to operate the blade lever.
- After each cutting operation, move the blade lever back to the starting position. Make sure the blade is locked
- Do not disassemble the front safety guard.
- Do not grasp beneath the blade edge.
- Strictly adhere to the instructions and use blade holders when changing the blade.
- Be sure the paper is free of metal parts such as paper clips and staples.

NOMENCLATURE

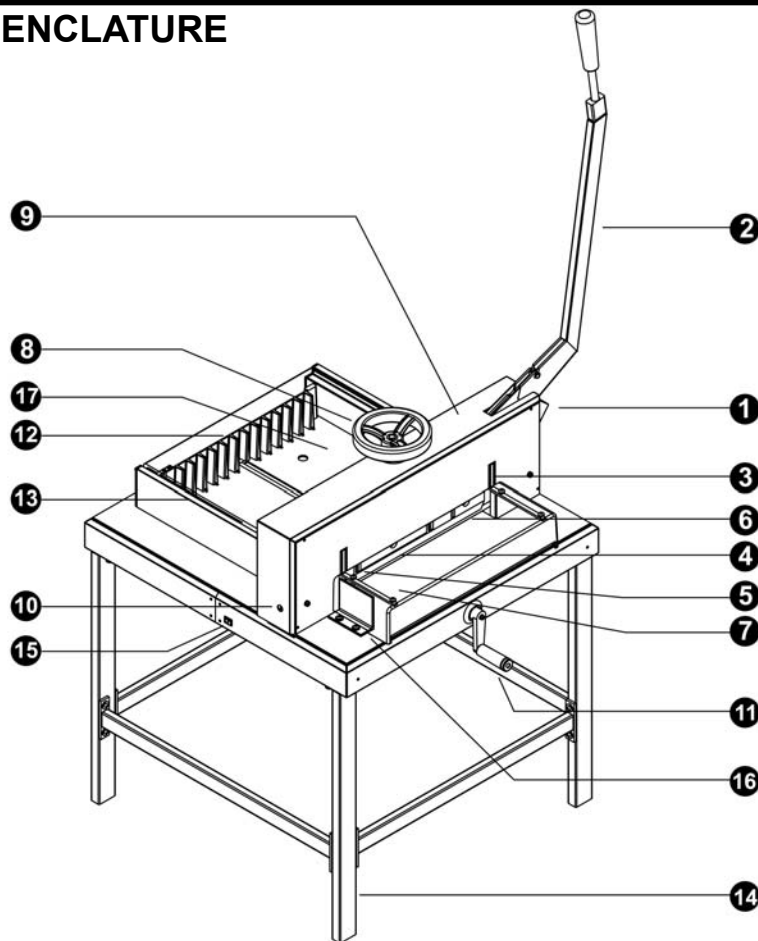

1. Safety cap
2. Blade lever
3. Blade locking device
4. Blade
5. Blade fastener
6. Cutting stick
7. Front safety guard
8. Clamping wheel
9. Cover
10. Blade adjustment
11. Back gauge crank
12. Back gauge
13. Side gauge with scale
14. Stand
15. Light switch
16. Paper alignment guide

COMPONENTS DESCRIPTION

1. Safety Cap

Warning! Pinch point. The safety cap is made of plastic and must be kept in place during operation in order to prevent serious injury.

2. Blade lever

Due to the optimal lever action, the blade lever enables cutting without effort. After each cutting operation the blade lever must be returned to its topmost position until it locks.

3. Blade locking device

The blade locking device secures the blade in its top position. A cutting operation can only be carried through when the front safety guard is in the down position releasing the locking device.

CAUTION: The blade locking device is controlled and connected with the front safety guard and the blade lever. You can open the front safety guard only when the blade lever is in its starting point.

4. Blade

Made of high carbon, quality steel. A sharp blade is important for the best performance.

WARNING! The blade is sharp. Use extreme caution when working with or near the blade.

5. Blade fastener

The blade fastener consists of 5 screws used to position the blade after cutting stick rotation or blade replacement.

6. Cutting stick

Made of tough plastic, the cutting stick is exchangeable. It may be used two times on each side (total 8 times).

7. Front safety guard

The front safety guard must be lowered before each cutting operation. Only then will the blade locking device be released. The front safety guard can be reopened only when the blade lever is locked in the top position.

WARNING! DO NOT *disassemble or make the front safety guard inoperative for any reason. Serious injury may occur.*

8. Clamping wheel

For pressing and holding the paper stack to be cut.

- ↻ Turn the clamping wheel clockwise to clamp the paper stack.
- ↻ Turn the clamping wheel counterclockwise to release the paper stack.

9. Cover

The cover is attached to the machine with four screws. Disassemble only in case of blade change or maintenance. Before removing the cover, first remove the safety cap.

10. Blade adjustment

The blade can be adjusted slightly by using the adjustment screw.

- ◀ Turn to the left (+): Adjust blade downward.
- ▶ Turn to the right (-): Adjust blade upwards.

Max. adjustment approx. 2mm

Note: A blade which is adjusted too deeply does not only damage the cutting stick but the blade itself. Optimal adjustment occurs when the last sheet is cut accurately.

11. Back Gauge Crank

The back gauge crank is indirectly connected with the back gauge. Connection is made by a slight push of the crank toward the machine. The connection is released when pulling the crank away from the machine.

- ↻ Turn the back gauge crank clockwise: the back gauge moves towards the blade.
- ↻ Turn the back gauge crank counterclockwise: the back gauge moves away from the blade.

The scale behind the back gauge crank serves for fine adjustment of the back gauge. Use the scale to set the back gauge when precision cuts are needed. One full turn of the crank represents one centimeter movement of the back gauge. The numbers on the dial represent millimeters and can be accurately set within .5mm increments.

12. Back Gauge

Operates with the back gauge crank. Adjusts the paper stack to the desired cutting size and for exact parallel cuts.

13. Side gauge with scale

Increments in millimeter, centimeter, and inch. Used for setting the back gauge to the desired paper size.

14. Stand

The stand is made of steel and is standard equipment with the chassis.

15. Light switch

When the light switch is on, a bright line will be visible on the paper stack to indicate the path of the blade.

16. Paper alignment guide

The paper alignment guide aligns the paper on the left side of the cutter. Made of steel.

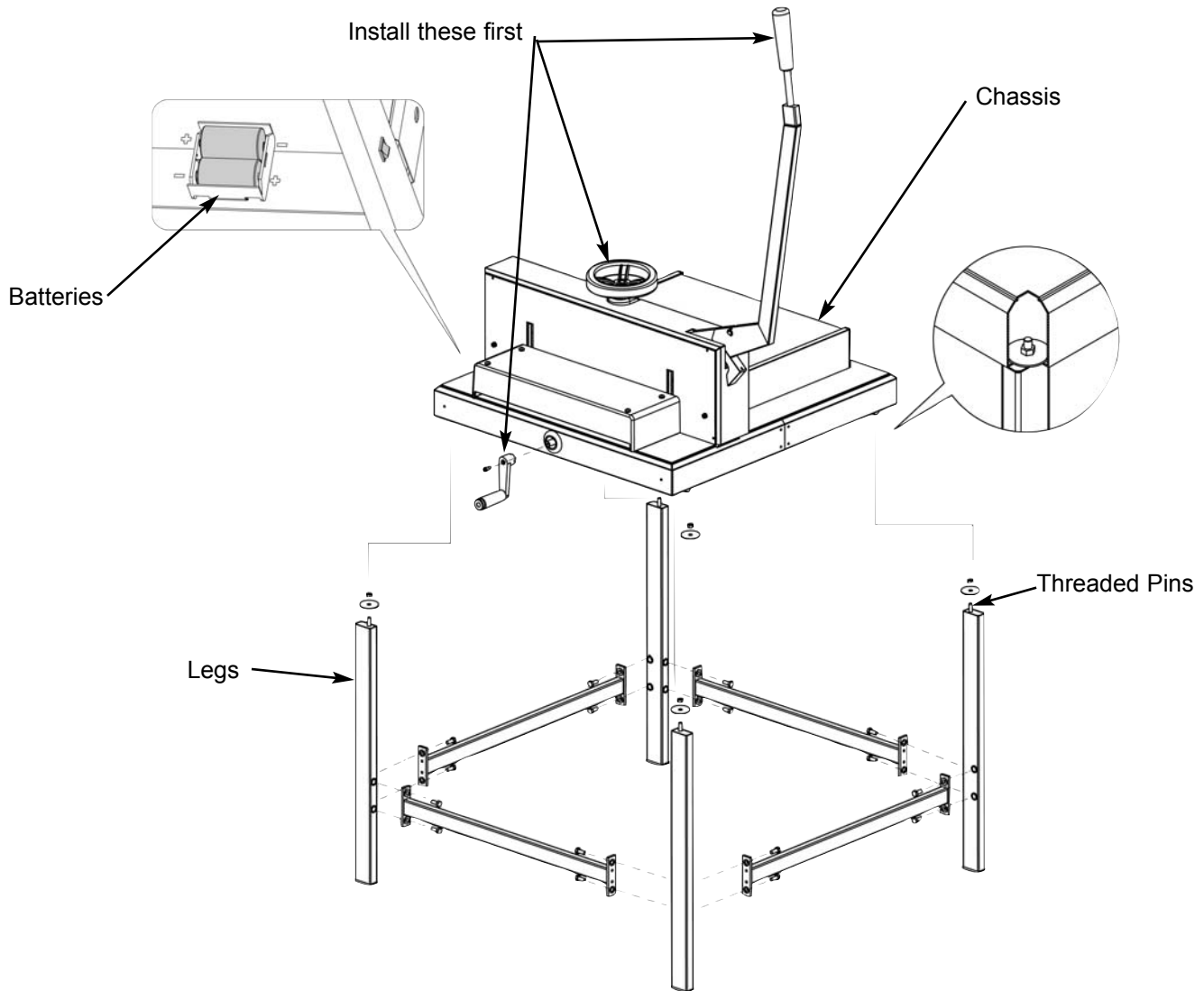

INSTALLATION

The grip of the blade lever (2), clamping wheel (8), and back gauge crank with screw (11) are packed separately in a box with the machine. Please install these parts right away. The chassis and stand of the machine should to be connected as follows:

1. Set up the legs in a way that the 4 threaded pins point upwards.
2. Assemble the stands by matching the color label on each corresponding part.
3. Place the chassis onto the assembled machine stand.
4. Fit the washer over the threaded pins and tighten the hexagonal nut using a 13 m/m wrench.
5. Fit two batteries (size D) into the battery holder on the underside of the chassis.

OPERATION

Do not attempt to operate the 620RC until you have read and thoroughly understand this manual. The following procedure should be followed when loading, cutting, and unloading paper from the 620RC.

1. Make sure the safety cap is in place and raise the blade lever until it is locked in its top position.
2. Lift the front safety guard and place the paper stack beneath the blade from the front of the trimmer. Push the paper stack along the paper alignment guide until it comes to rest squarely against the back gauge and side gauge with scale.
3. Push the back gauge crank toward the cutter to engage. Turn the crank handle clockwise to bring the back gauge toward the blade until the desired paper measurement is reached. Use the fine adjustment scale behind the back gauge crank to insure accurate measurement to within .5mm.

4. Release the back gauge crank (away from cutter), so that the unintentional movement of the back gauge can be prevented.
5. Turn the clamping wheel clockwise to clamp the paper stack tight. Excessive clamp pressure may cause the stock to be creased. The use of waste sheets above and below the stock to be cut is a common protection method used to keep the finished stock from being marked or creased. If additional clamping pressure is required the blade may need to be sharpened. Continuing to cut with a dull blade may cause severe damage to the cutting mechanism or handle.
6. Lower the front safety guard completely to disengage the blade locking device.
7. Use both hands to bring down the blade lever to make the cut. When the cut is complete, move the blade lever to its top position until it locks.
8. Turn the clamping wheel counterclockwise to release the paper stack. Lift the front safety guard and remove the paper stack from the cutter.

BLADE SHARPENING

Dulling of the blade is a natural occurrence and is determined primarily by the type of material being cut. Blade life with normal paper is approximately 600 cuts (tested in maximum capacity). This will vary for different types of paper. Many paper products today are made of re-cycled materials and can be very abrasive to the blade. If it becomes increasingly more difficult to cut paper, the cut is rough, or if excessive clamp pressure is required to hold the stack, then it is time to sharpen the blade (see page 7). Always keep a spare blade on hand to use while you send out the dull one to be sharpened by a qualified blade sharpener or machine shop.

WARNING! *The cutting edge of the blade is extremely sharp. In order to reduce the possibility of injury, the blade change should be executed by one person and the blade must be handled with the utmost care. Please follow the blade replacement instructions exactly.*

CUTTING STICK

Gradual wearing of the cutting stick is normal during machine operation. As a groove is formed in the stick by the cutting action of the blade, the blade may not completely cut through the bottom sheets of the stack. When this condition occurs, rotate the cutting stick, or replace, if necessary. The design of the Model 620RC cutting stick allows rotation to eight cutting locations. (The stick may be rotated to four surfaces and reversed from end to end.) To rotate the stick proceed as follows:

1. Raise the blade lever until it is locked in its topmost position. Raise the front safety cover. Open the paper clamp by turning the clamping wheel counterclockwise until it stops.
2. A hole in the cutting stick fits over a pin in the left side of the channel beneath the clamp to hold the cutting stick in place. Carefully lift up the right end of the cutting stick.
3. Place a flat tip screwdriver under the raised end of the cutting stick and slide it under the length of the stick to completely remove it off the pin and from the channel.
4. Rotate the stick to a new surface and place it back into the channel. Make sure the hole in the end of the cutting stick fits around the pin in the channel. When all four surfaces have been used, reverse the stick end to end and repeat the rotation process as needed. Replace the stick when a correctly adjusted new, or resharpened blade will no longer cut through the bottom sheet of a stack and all surfaces have been used.

Note: When the cutting stick is changed, the blade must be readjusted. A blade which cuts too deeply damages not only the cutting stick but the blade also. Adjust the blade as described on page 8 (steps 18-21).

LUBRICATION

The mechanical components of the cutter require periodic lubrication depending upon cutter use. Before lubricating, these parts should be cleaned of paper dust and old deposits of oil and grease.

MAINTENANCE

Check all screws on moving parts periodically (or after every 200 cuts) to insure they have not loosened during transportation or with continued use. The on-schedule maintenance will prolong the life of each part and prevent possible down-time.

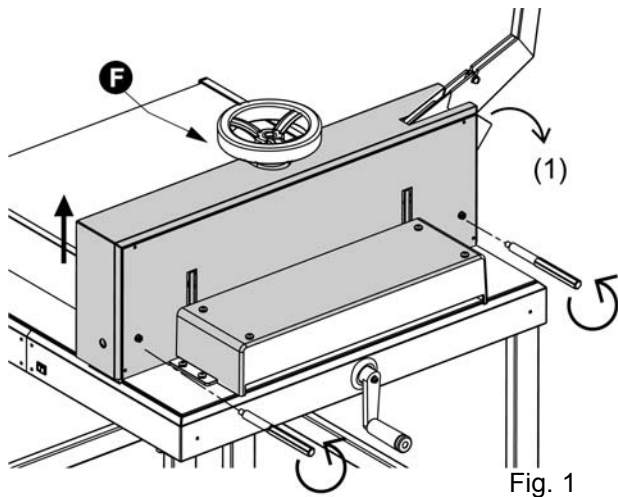

Fig. 1

Blade Replacement Instruction

WARNING! *The cutting blade is extremely sharp. Serious bodily harm can result from mishandling.*

- (1) Remove the safety cap.
- (2) Move the blade lever to its topmost position.
- (3) Remove the screw (F) on the clamp wheel and detach the wheel from the chassis. (Fig. 1)
- (4) Remove all screws from the cover.
- (5) Place the blade lever at 75° to table and take off the cover.
- (6) Lower the blade lever to its horizontal position. (Fig. 2)

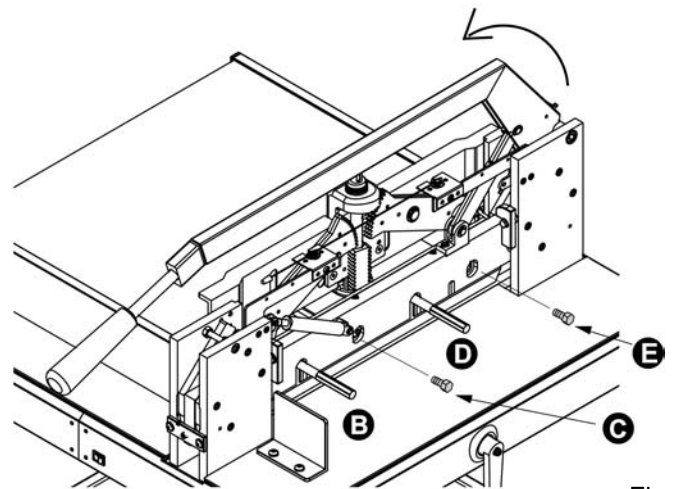

Fig. 2

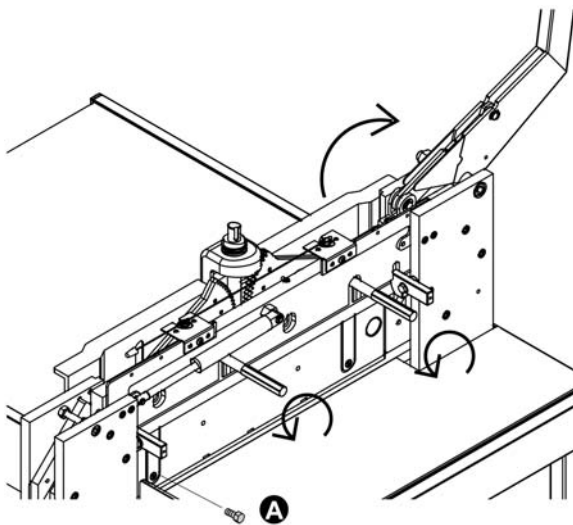

Fig. 3

- (7) Remove the blade screws (B) and (D) and replace them with the two blade holders from the tool box. Tighten them securely.
- (8) Take out blade screws (C) and (E).
- (9) Return the blade lever to its starting position and lock it.
- (10) Take out the blade screw (A). (Fig. 3)
- (11) Loosen blade holders (only half turn) and lower the blade downward from the blade carrier. Take out the blade carefully. Secure the blade so the sharp edge will not be exposed and remove the blade holder tools. **NOTE:** To prevent damaging the blade, do not let the blade edge contact any surface except the cutting surface or blade carrier. (Fig. 4)
- (12) Remove the blade holders from the dull blade. Screw the two blade holders into the new blade. (Fig. 5)
- (13) Insert the blade holders into the opened second and fourth hole (B) and (D) of the blade carrier and fasten securely. (Fig. 6)
- (14) Lower the blade lever to its horizontal position.

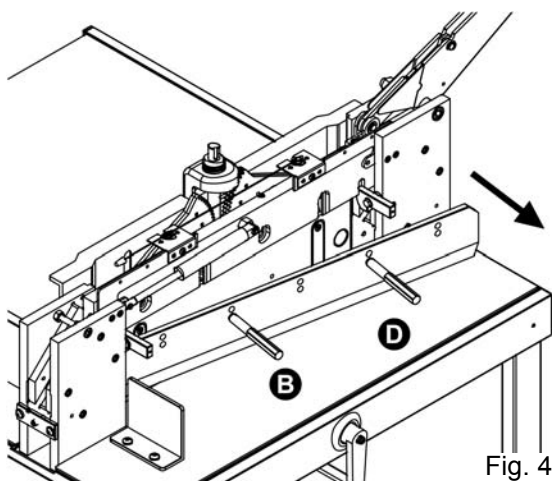

Fig. 4

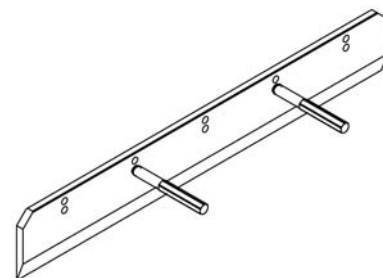

Fig. 5

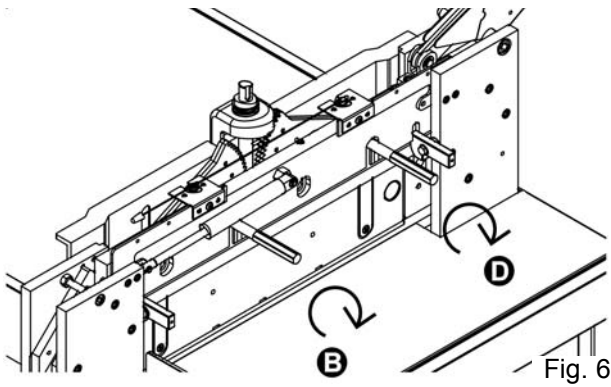

Fig. 6

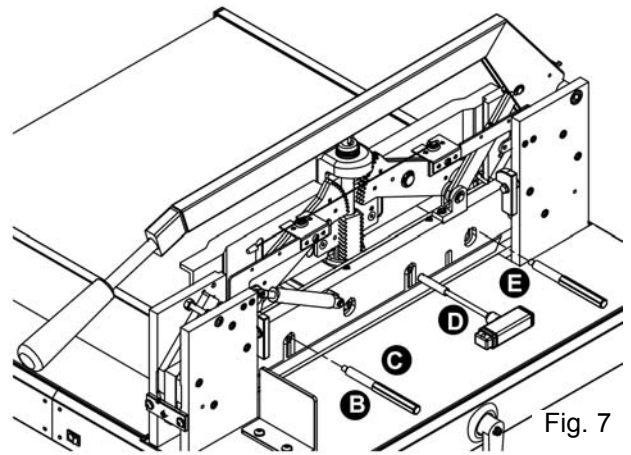

Fig. 7

- (15) Replace blade screws (C) and (E). Remove the blade holders. Replace blade screws (B) and (D).
- (16) Return the blade lever to its starting position and lock it.
- (17) Screw in blade screw (A).
- (18) Using the blade lever, lower the blade carefully down to the cutting stick.
- (19) Turn the blade adjustment (Z) to the right (-) until you have a visible ray of light between the blade edge and the cutting stick. (Fig. 8)
- (20) Adjust the blade to touch the cutting stick evenly by adjusting the 3 blade screws (Y).
- (21) Once again, return the blade lever to its starting position and lock it. Make a trial cut with one sheet of paper. If the paper is not cut through completely, the blade must be readjusted with the adjusting screws (Y) and (Z).

NOTE: The three (Y) screws are for horizontal adjustment. The (Z) screw is for minor up-down adjustment.

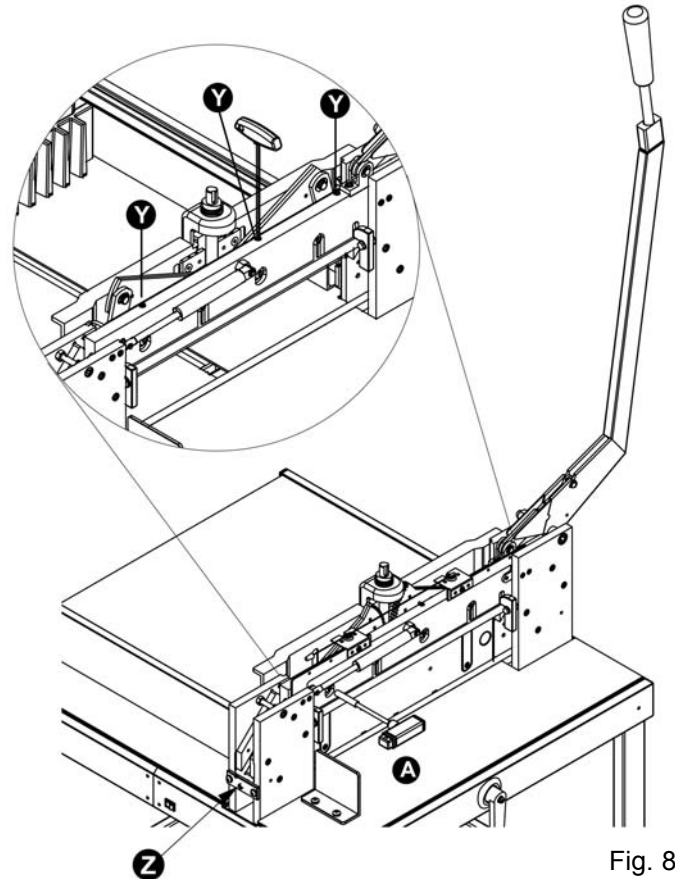

Fig. 8

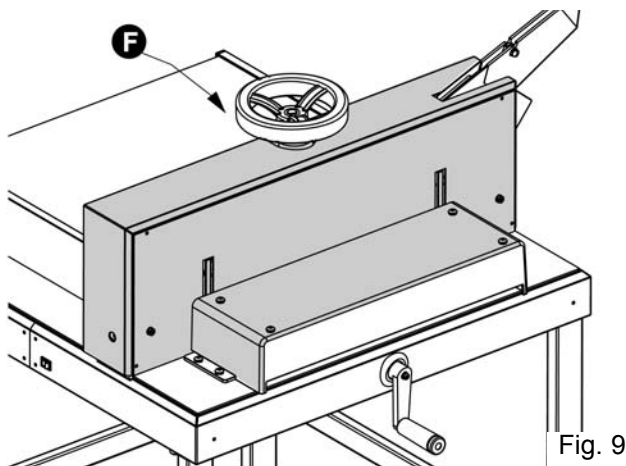

Fig. 9

- (22) Place the blade lever at 75° to table and replace the cover and screws. (Fig. 9)
- (23) Reattach the clamping wheel and screw (F).
- (24) Assemble the safety cap.



MARTIN YALE
Industries

251 Wedcor Avenue • Wabash, IN 46992
Phone (260) 563-0641 • Fax (260) 563-4575
Website: www.martinyale.com
Email: info@martinyale.com

7/14/2004